

SFERA MAGNETICA A SOSPENSIONE- 24V - 7W

SUSPENSION MAGNETIC SPHERE- 24V - 7W

ART: MOS08LBC/NE - MOS08LBC/BI
MOS08LBN/NE - MOS08LBN/BI

Destinazione d'uso | Use:

Interni | Indoor

Installazione | Installation:

Su binario magnetico Micro
On Micro magnetic track

Trattamento | Processing:

Verniciato a polveri
Powder coated

Corpo / Struttura | Body / Structure:

Pressofusione di alluminio
Aluminum die casting

Fissaggio | Fixing:

Modulo magnetico
Magnetic module

Alimentazione | Power Supply:

ON/OFF a bordo
ON/OFF on board

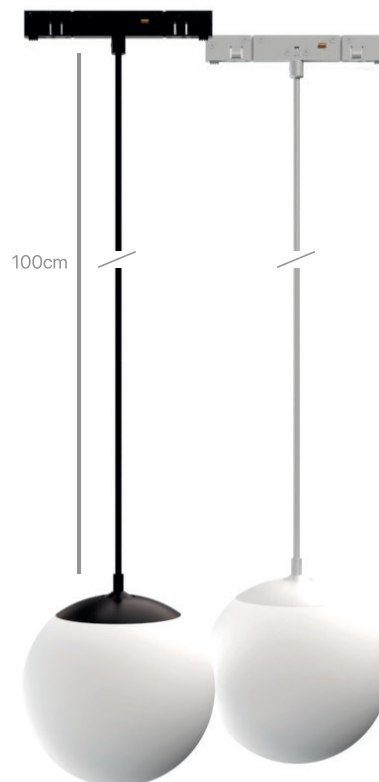

Tensione / Voltage: 24 Vdc

Peso / Weight: 150 gr

Grado IP / IP Rating: 20

Filo Incandescente / Glow Wire: ... 650 C°

Tipo Led / Led Type: SMD BRIDGELUX

Potenza Lampada / Lamp Power: ... 7W

Flusso Lampada / Lamp Flow: 590 | 610 lumen

Temperatura di colore
Color temperature 3000K | 4000K

Indice di resa cromatica
Color rendering index: CRI95

